

## Parts List

- 1-Folding Windshield – Hinged
- 1-Acrylic Windshield Valance
- 2-Self-Gripping Vinyl Edge Trim “U” Shaped
- 1-Self-Gripping Rubber Bottom Bulb Seal
- 1-Windshield Mounting Kit: (4) Steel Post Clamps With Locknuts, (4) Rubber Flat Washers, (4) Thumb Drives With Molded Knob
- 1-Upper Retaining Kit: (2) Rubber Strap Latches, (2) Black Zinc Latch Plates, (4) ¼-20x1 ¾” Phil Pan Machine Screws, (4) 5/16” Flat Washers, (4) ¼-20 Locknuts, (4) Rubber Grommets
- 1-Lower Retaining Kit: (2) Black Powder Coated Retaining Brackets With Tab
- 1-Valance Kit- (4) Cable Clamps, (4) ¼-20x1/2” Truss Phil Machine Screws, (8) 5/16” Flat Washers, (4) Slotted Connector Nut ¼-20”, (4) Rubber Grommets

## Tools Required

- Ratchet
- Socket – 7/16”
- Wrench – 7/16”
- Screwdriver – Phillips Head
- Screwdriver – Flat Head



**Step 1** Install Four Steel Post Clamps (Two Per Side) As Shown In (Fig 1). The Bottom Clamp On Each Side Will Be Installed Below A The Bend At The Bottom Of The Roll Cage (Resting on Top Of The Weldment Bead). The Upper Clamp Will Be Installed Approximately 8 1/2” Inches “Up” The Cage From The Lower Steel Post Clamp.

**Note: Do Not Tighten All The Way At This Time, So That The Exact Positions Of The Clamps Can Be Determined At The Time That The Windshield Is Fully Installed. These Clamps Will Line Up With The Four Slots In The Bottom Of The Windshield.**

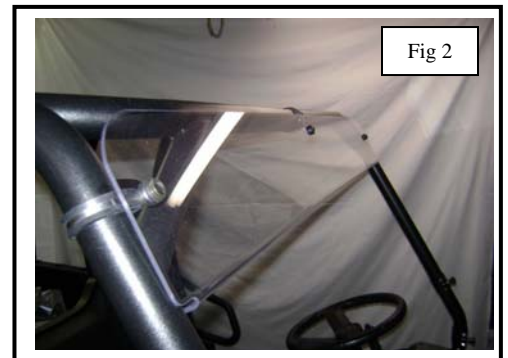

**Step 2** Remove Protective Film From Acrylic Valance And Install As Shown In (Fig 2) Using Hardware From Valance Kit. See (Fig. 2a) For Exact Stacking Of Hardware. The Grommets Will Be Inserted Into The Three Holes In The Valance & Worked Around Until The Grommets Completely Encapsulate Both Surfaces Of The Glass. (Fig 6) Illustrates This As Well. **Note : The Valance Should Be Installed With The Bend Or “Lip” Facing Inward Toward The Driver & Passenger.**

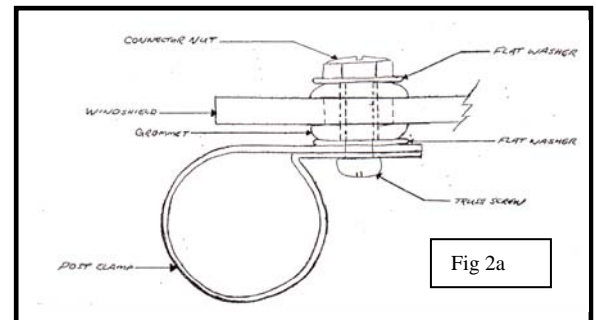

**Step 3** Remove Protective Film From Bottom Section Of Windshield & Install Rubber Bottom Bulb Seal As Shown In (Fig 3 and Fig 4). **Note: The Sealing Edge Of The Bulb Seal Should Lay On The Cowl Cap Facing The Front Of The Vehicle Pointing Away From The Driver and Passenger As Shown In (Fig 4)**

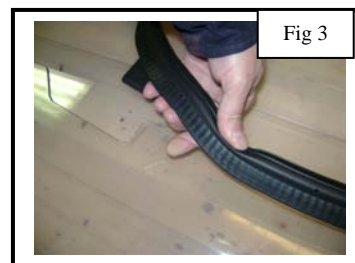

**Step 4** Place The Windshield Against The Roll Cage & Align All 4 Slots In Bottom Half With The Center Holes In The Steel Post Clamps. Run The Thumb Drives With Molded Knob Through The Windshield & Into The Threaded Holes In The Steel Post Clamps (Fig 5). **Note: Remember To Include The Rubber Washers Between The Base Of The Knob On The Thumb Drive & The Windshield. (Fig 5a)**

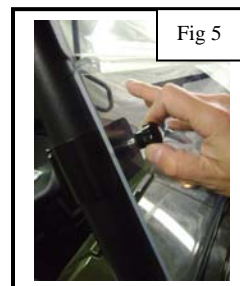



www.jstrongindustries.com  
Toll free 877-444-4147

**Step 5** Remove The Protective Film From The Top Half Of The Windshield & Locate The Four Rubber Grommets & The Corresponding Machined Holes On The Windshield (Two Per Side In The Upper Corners) Which Will Be Protected By The Grommets. Insert These Grommets Into The Holes And Work Them Around The Hole Until The Grommet Encapsulates Both Surfaces Of The Glass (**Fig 6**). Next, Install The Rubber Strap Clamp Over The Grommets On The Inner Surface Of The Windshield (Facing Driver & Passenger) And Run The 1/4-20x1 3/4" Bolts & 5/16" Flat Washers Thru The Outside Grommets & The Windshield. See (**Fig 7**).

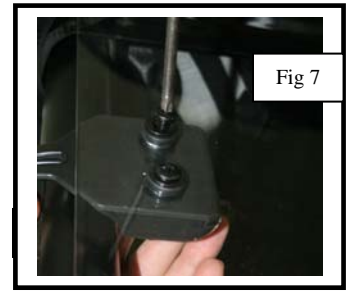
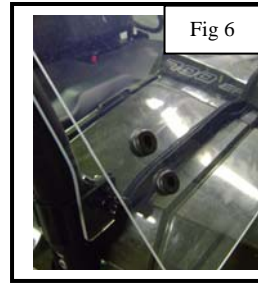

**Step 6** Unfold The Windshield So That It Is In The "Up" Or "Closed" Position & Place The Latch Plate On The Back Side Of The Rubber Strap Clamp. The Tabbed End Of The Latch Plate Should Face The Center Of The Windshield. Adjust The Alignment Of The Rubber Strap Clamp & Latch Plate By Sliding The Latch Plate Back Until The Trailing Edge Of The Plate Hits The Raised Ridge On The Rubber Strap Clamp (**Fig 8**). Secure With 1/4-20" Locknuts. Repeat This Process For The Installation Of The Other Rubber Strap Clamp & Latch Plate. **Tighten All Bolts At This Time. Do Not Over Tighten The Thumb Drive. Make Sure That The Rubber Washer Is Between The Thumb Drive & The Windshield.**

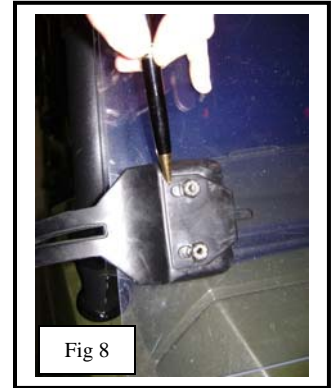

**Step 7** Install The Vinyl Edge Trim Along The Interior Lip Of The Windshield Located Just Below The Hinge (**Fig 9**). **Note: Make Sure The Edge Trim Is Firmly Seated By Pushing On The Outside Edge Of The Trim Until The Windshield Hits The Bottom Of The "U" Shaped Channel.** Repeat The Process By Installing The Second Piece Of Vinyl Edge Trim On The Bottom Interior Lip Of The Valance Installed In **Step 2**.

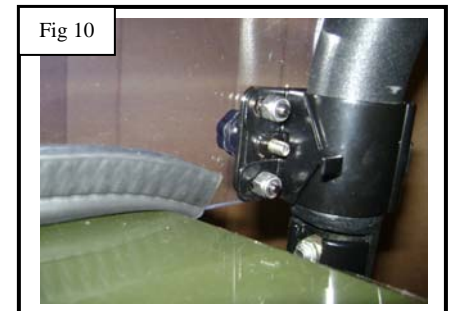

**Step 8** Make Sure That The Windshield Is In The "Up" or "Closed" Position. Loosen & Remove The Locknuts Holding The Lower Most Steel Post Clamps In Place On Each Side (The Steel Post Clamps Closest To The Bend At The Bottom Of The Roll Cage). **Note: You Can Leave The Thumb Drive in Place That Is Holding The Windshield To The Steel Post Clamps.** Next, Locate The (2) Black Powder Coated Retaining Brackets With Tabs From The Lower Retaining Kit And Install Them Over The Studs In The Steel Post Clamps Where The Locknuts Have Just Been Removed (**Fig 10 & Fig 11**). The Slots On The Brackets Correspond With The Studs In The Steel Post Clamps. Note: Please Position The Retaining Brackets With The Tabs Facing Inward Toward The Center Of The Windshield. Essentially, The Two Tabs Will Be Pointing Toward Each Other. Use The Locknuts From The Steel Post Clamps To Secure The Brackets To The Clamps. The Brackets Will Be Used To Hold The Windshield In The "Down" Or "Folded" Position By Stretching The Rubber Strap Clamp Around The Roll Cage In The Opposite Direction And Hooking It Onto The Tab On The Bracket.



**Your Windshield Is Now Complete!**

**WARNING: Disclaimer: Under no circumstances will J.Strong Industries or their parent companies accept liability for incidental or consequential damages. J.Strong windshields are not applicable, nor should the windshield be considered as protection against rollover, collision or other accidents that may result. Extreme care should be taken when operating a motorized vehicle and should only be operated by qualified, experienced operators**