

EK406 Instructions for JStrong Polaris Ranger

Parts List: (See FIG 1)

- 4- 1/4-20" Bolts
- 4- 1/4" Flat washers
- 4- 1/4" Large flat washers
- 4- Self drilling screws
- 4- Mounting Clamps



Tools Needed:

- Drill with 3/8" drill bit
- 13mm wrench
- 5mm Allen wrench

Toll Free 1-877-444-4147
www.Jstrongindustries.com

Step 1:

Park the unit on a level surface. Set the parking brake. Stop the engine and remove the key.

Step 2:

Place the top on the roll cage. Center the top left to right and push the top as far forward as it will slide.

Step 3:

Position the clamp on the roll cage as shown in FIG 2. Hold it tightly against the top and drill a 3/8 diameter hole through the top in the middle of the slot in the clamp. Repeat this for all four (4) clamps. (Units prior to 2009, refer to sht 2 for clamp position)

Step 4:

Assemble the large flat washer to the bolt. Insert this assembly through one of the four holes in the top. Position the clamp around the crossbar and align the clamp slot with the bolt as it comes through the hole in the top.

Step 5:

Assemble a flat washer and nylon locking nut on each of the four bolts protruding through the clamps. Do not tighten at this time. (If you are installing the top on a unit built prior to 2009 proceed to Step 5a on sheet 2 before going to Step 6)

Step 6:

Center the top again and tighten all four bolts and nuts.

Step 7:

Insert a self drilling screw through the holes in the four clamps and drill them into the roll cage tightly.

Step 8:

Hook the white 10 gauge wire to (+) the positive post on the battery and the black wire to the (-) negative post on the battery.

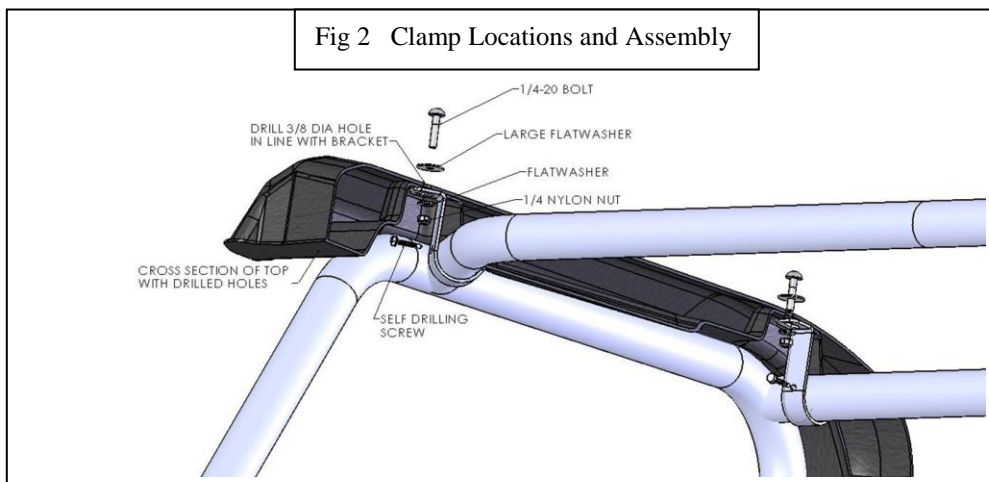

Warning: Disclaimer: Under no circumstances will JStrong Industries or their parent companies accept liability for incidental or consequential damages. JStrong reminds you extreme care should be taken when operating a motorized vehicle and should only be operated by qualified, experienced operators.