

Parts List

- 1-Folding Windshield – Hinged
- 1-Acrylic Windshield Valance
- 2-Self-Gripping Vinyl Edge Trim “U” Shaped
- 1-Self-Gripping Rubber Bottom Bulb Seal
- 1-Windshield Mounting Kit: (4) Steel Post Clamps With Locknuts, (4) Rubber Flat Washers, (4) Thumb Drives With Molded Knob
- 1-Upper Retaining Kit: (2) Rubber Strap Latches, (2) Black Zinc Latch Plates, (4) 1/4-20x1 3/4” Phil Pan Machine Screws, (4) 5/16” Flat Washers, (4) 1/4-20 Locknuts, (4) Rubber Grommets
- 1-Lower Retaining Kit: (2) Injection Molded Hood Spools, (2) M6-35 Phil Pan Machine Screws, (2) Clear Zinc Fender Washers, (2) Clear Zinc M6 Locknuts
- 1-Valance Kit- (4) Cable Clamps, (4) 1/4-20x1/2” Truss Phil Machine Screws, (8) 5/16” Flat

Tools Required

- Drill & 1/4” Bit
- Ratchet & 7/16” Socket
- Wrench – 6MM
- Wrench – 7/16”
- Screwdriver – Phillips Head
- Screwdriver – Flat Head

www.jstrongindustries.com
Toll free 877-444-4147



Step 1 Install Four Steel Post Clamps (Two Per Side) As Shown In (Fig 1). **Note: Do Not Tighten All The Way At This Time, So That The Exact Positions Of The Clamps Can Be Determined At The Time That The Windshield Is Fully Installed. These Clamps Will Line Up With The Four Slots In The Bottom Of The Windshield.**



Shown In (Fig 2) Using Hardware From Valance Kit. See (Fig. 2a) For Exact Stacking Of Hardware. The Grommets Will Be Inserted Into The Four Holes In The Valance & Worked Around Until The Grommets Completely Encapsulate Both Surfaces Of The Glass. (Fig 6) Illustrates This As Well. **Note : The Valance Should Be Installed With The Bend Or “Lip” Facing Inward Toward The Driver & Passenger.**

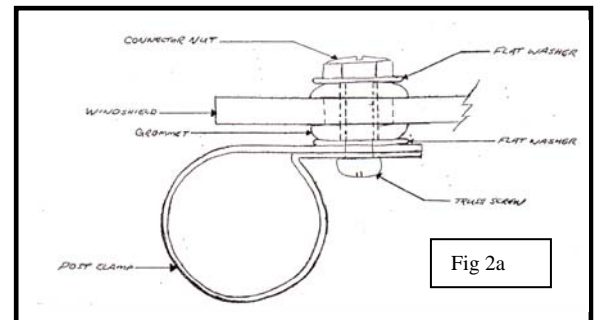

Step 3 Remove Protective Film From Bottom Section Of Windshield & Install Rubber Bottom Bulb Seal As Shown In (Fig 3 and Fig 4). **Note: The Sealing Edge Of The Bulb Seal Should Lay On The Cowl Cap Facing The Front Of The Vehicle Pointing Away From The Driver and Passenger As Shown In (Fig 4)**

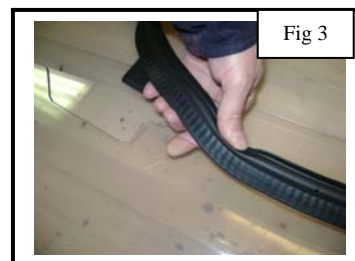

Step 4 Place The Windshield Against The Roll Cage & Align All 4 Slots In Bottom Half With The Center Holes In The Steel Post Clamps. Run The Thumb Drives With Molded Knob Through The Windshield & Into The Threaded Holes In The Steel Post Clamps (Fig 5). **Note: Remember To Include The Rubber Washers Between The Base Of The Knob On The Thumb Drive & The Windshield. (Fig 5a)**

